

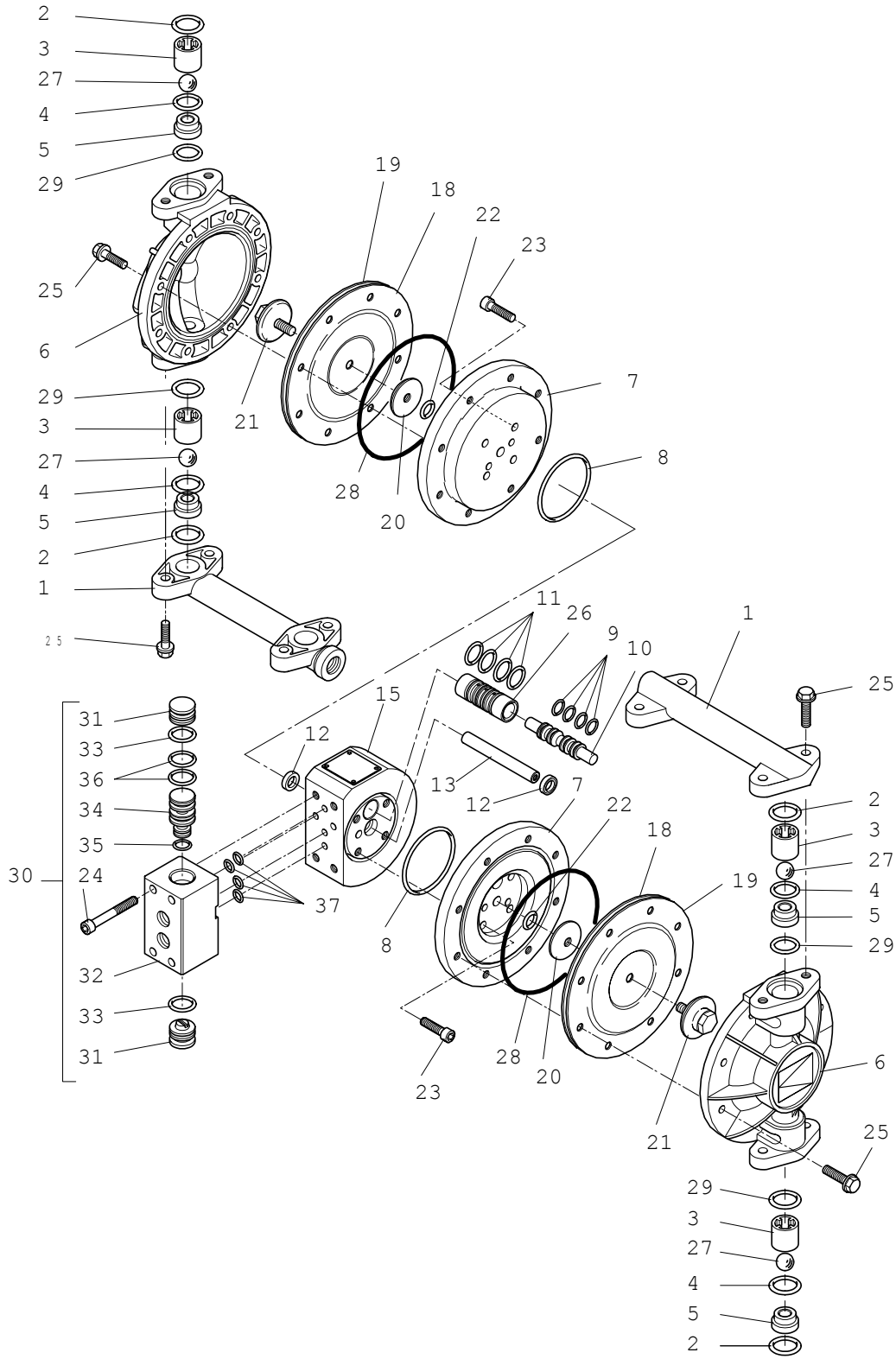

<p>Doc. 573.249.050 Date/Datum/Fecha : 3/03/08 Annule/Cancela/ Ersetzt/Anula : 20/12/04</p>	<p>Modif. /Änderung : # Ind. 27 (option /opción)</p>	<p>Pièces de rechange Spare parts list Ersatzteilliste Piezas de repuesto</p>
---	---	---



POMPE A MEMBRANES NUE, modèle PMP 150 STANDARD	BARE DIAPHRAGM PUMP, model PMP 150 STANDARD	#
MEMBRANPUMPE NACKT, Modell PMP 150 STANDARD	BOMBA DE MEMBRANAS SOLA, tipo PMP 150 STANDARD	144.931.000

Ind	#	Désignation	Description	Bezeichnung	Denominación	Qté
1	044.931.002	Collecteur	Collector	Verbindungsflansch	Colector	2
2	150.040.315	Joint PTFE (les 10)	Seal, PTFE (pack of 10)	Dichtring PTFE (10 St.)	Junta PTFE (x 10)	4
* 3	144.931.093	Cage de bille plastique (les 4)	Ball cage, plastic (pack of 4)	Kugelkäfig, Kunststoff (4 St.)	Jaula de bola de plástica (bolsa de 4)	4
4	150.040.316	Joint PTFE (les 10)	Seal, PTFE (pack of 10)	Dichtring PTFE (10 St.)	Junta PTFE (bolsa de 10)	4
5	044.931.004	Siège inox	Seat, stainless steel	Sitz, Edelstahl	Asiento inox	4
6	044.931.005	Flasque produit	Flange, fluid	Materialflansch	Tapa producto	2
7	044.931.001	Flasque moteur	Flange, air motor	Motorflansch	Tapa motor	2
8	109.420.282	Joint O Ring (les 10)	O Ring (pack of 10)	O-Ring (10 St.)	O Ring (bolsa de 10)	2
9	109.130.410	Bague R8 (les 10)	Ring, R8 (pack of 10)	Dichtring R8 (10 St.)	Anillo R8 (bolsa de 10)	4
10	044.930.003	Tiroir de pilotage	Pilot -spool	Steuerstange	Cajón de pilotaje	1
11	109.420.283	Joint O Ring (les 10)	O Ring (pack of 10)	O-Ring (10 St.)	Junta O Ring (bolsa de 10)	4
12	109.060.301	Joint (les 10)	Seal (pack of 10)	O-Ring (10 St.)	Junta (bolsa de 10)	2
13	044.930.004	Axe de liaison	Coupling axis	Verbindungsachse	Eje de unión	1
15	144.930.001	Corps moteur	Body, air motor	Motorkörper	Cuerpo del motor	1
* 17	144.931.090	Kit membranes	Diaphragm kit	Membrankit	Kit membranas	1
18	NCS / NSS	▪ Membrane air	▪ Diaphragm (air)	▪ Luftmembran	▪ Membrana aire	2
19	NCS / NSS	▪ Membrane produit PTFE	▪ Diaphragm (fluid), PTFE	▪ Materialmembran PTFE	▪ Membrana producto , PTFE	2
28	109.420.272	▪ Joint (les 10)	▪ Seal (pack of 10)	▪ O-Ring (10 ST.)	▪ Junta (bolsa de 10)	2
20	044.930.007	Rondelle air	Washer, air	Scheibe	Arandela aire	2
21	044.931.008	Vis-rondelle produit	Screw-washer, fluid	Membranschraube Material	Tornillo-arandela producto	2
22	909.130.411	Bague R 9	Ring, R 9	O-Ring	Anillo R 9	2
23	933.151.277	Vis CHc M 6 x 20	Screw, CHc M 6 x 20	Schraube CHc M 6 x 20	Tornillo CHc M 6 x 20	8
24	930.151.598	Vis CHc M 6 x 60	Screw, CHc M 6 x 60	Schraube CHc M 6 x 60	Tornillo CHc M 6 x 60	4
25	933.231.332	Vis M 6 x 25	Screw, M 6 x 25	Schraube M 6 x 25	Tornillo M 6 x 25	24
26	044.930.005	Chemise de pilotage	Sleeve, pilot-spool	Steuerstangenführung	Camisa de pilotaje	1
* 27	144.849.901	Bille Ø 16 inox 440C (les 4)	Ball Ø 16, stainless steel 440C (pack of 4)	Kugel Ø 16 Edelstahl 440C (4 St.)	Bola Ø 16 inox 440C (bolsa de 4)	4
29	129.629.914	Joint PTFE (les 10)	Seal, PTFE (pack of 10)	O-Ring PTFE (10 St.)	Junta PTFE (x 10)	4

Ind	#	Désignation	Description	Bezeichnung	Denominación	Qté
* 30	144.930.010	Distributeur d'air	Air distributor	Lufteinheit	Distribuidor de aire	1
31	044.930.013	▪ Bouchon	▪ Plug	▪ Stopfen	▪ Tapón	2
32	044.930.011	▪ Corps de distributeur	▪ Body, distributor	▪ Umsteuerblockkörper	▪ Cuerpo del distribuidor	1
33	129.400.902	▪ Joint O Ring (les 10)	▪ O Ring (pack of 10)	▪ O-Ring (10 St.)	▪ Junta O Ring (bolsa de 10)	2
34	044.930.012	▪ Tiroir de puissance	▪ Air valve, spool	▪ Umsteuerventil	▪ Cajón de potencia	1
35	109.130.410	▪ Bague R 8 (les 10)	▪ Ring, R 8 (pack of 10)	▪ O-Ring R8 (10 St.)	▪ Anillo R 8 (bolsa de 10)	1
36	144.519.915	▪ Bague R 12 (les 10)	▪ Ring, R 12 (pack of 10)	▪ O-Ring R12 (10 St.)	▪ Anillo R 12 (bolsa de 10)	2
37	144.579.910	▪ Bague R 6a (les 10)	▪ Ring, R 6a (pack of 10)	▪ O-Ring R6a (10 St.)	▪ Anillo R 6a (bolsa de 10)	4
-	901.180.024	Câble de mise à la terre (lg. 5m) avec rondelle et vis	Ground with washer and screw (length : 5 m / 16.4 ft)	Erdungskabel (L. 5m) mit Scheibe und Schraube	Cable de toma a tierra (5 m de largo) con arandela y tornillo	1

POMPE PMP 150 E (pour produits à base d'email)	PUMP, MODEL PMP 150 E (for enamel based products)	# 144.932.000
PUMPE PMP 150 E (für Produkte auf Email-Basis)	BOMBA, tipo PMP 150 E (para productos a base de esmalte)	

Ind	#	Désignation	Description	Bezeichnung	Denominación	Qté
		Pièces spécifiques à la pompe PMP 150 E	Specific parts for pump, model PMP 150 E	Spezifische Teile der Pumpe PMP 150 E	Partes específicas para bomba tipo PMP 150 E	
5	044.932.004	Siège polyuréthane	Seat, polyurethane	Sitz aus Polyuräthan	Asiento poliuretano	4
* 17	144.932.090	Kit membranes (2 membranes produit + ind. 19 en polyuréthane)	Diaphragm kit (2 fluid diaphragms + ind. 19 - polyurethane)	Membrankit (2 Material-membrane + Pos. 19 aus Polyuräthan)	Kit membranas (2 membranas producto + ind. 19 de poliuretano)	1
27	144.849.910	Bille Ø 16 en polyuréthane (les 4)	Ball Ø 16 polyurethane (pack of 4)	Kugel Ø 16 aus Polyuräthan (4 St.)	Bola Ø 16 de poliuretano (bolsa de 4)	4

PMP 150 STANDARD - PMP 150 E

Ind	#	Désignation	Description	Bezeichnung	Denominación	Qté
*	144.931.091	Pochette de joints moteur + joints distributeur d'air (ind. 8(x2), 9(x4), 11(x4), 12(x2), 22(x2), 28(x2), 33(x2), 35, 36(x2), 37(x4))	Package of seals of the air motor+ seals of the air distributor (ind. 8(x2), 9(x4), 11(x4), 12(x2), 22(x2), 28(x2), 33(x2), 35, 36(x2), 37(x4))	Dichtungssatz Motor + Lufteinheit (Pos. 8(x2), 9(x4), 11(x4), 12(x2), 22(x2), 28(x2), 33(x2), 35, 36(x2), 37(x4))	Bolsa de juntas del motor + juntas del distribuidor de aire (ind. 8(x2), 9(x4), 11(x4), 12(x2), 22(x2), 28(x2), 33(x2), 35, 36(x2), 37(x4))	1
*	144.931.092	Pochette de joints produit en PTFE (ind. 2(x4), 4(x4), 29(x4))	Package of seals, fluid (PTFE seals) (ind. 2(x4), 4(x4), 29(x4))	Dichtungssatz Material aus PTFE (Pos. 2(x4), 4(x4), 29(x4))	Bolsa de juntas producido PTFE (ind. 2(x4), 4(x4), 29(x4))	1
*	144.931.094	Pochette de joints distributeur d'air (ind. 33(x2), 35, 36(x2), 37(x4))	Package of seals of the air distributor (ind. 33(x2), 35, 36(x2), 37(x4))	Dichtungssatz Lufteinheit (Pos. 33(x2), 35, 36(x2), 37(x4))	Bolsa de juntas del distribuidor de aire (ind. 33(x2), 35, 36(x2), 37(x4))	1

- * Pièces de maintenance préconisées tenues en stock.
- * Preceding the index number denotes a suggested spare part.
- * Bezeichnete Teile sind empfohlene Ersatzteile.
- * Piezas de mantenimiento preventivo a tener en stock.

- N C S : Non commercialisé seul.
- N S S : Denotes parts are not serviceable separately.
- N S S : bezeichnete Teile gibt es nicht einzeln, sondern nur komplett .
- N S S : no suministrado por separado.

EN OPTION - OPTIONAL - OPTION - OPCIÓN

Ind	#	Désignation	Description	Bezeichnung	Denominación	Qté
27	907.414.142	Bille Ø 16 (inox 316L)	Ball Ø 16 (stainless steel, 316L)	Kugel, Ø 16 (Edelstahl 316L)	Bola Ø 16, (inox 316L)	1

Alimentation d'air

Air supply

Luftausrüstung

Equipo de aire

151.753.050

